



# Control technology and software

IT-powered automation



## IT-powered automation

Industrial machines and systems must satisfy ever-increasing requirements for flexibility, performance, and networking. Phoenix Contact therefore develops innovative solutions that allow you to use IT technologies in industrial applications. This means that the production department and the office can communicate seamlessly with each other, processes are more transparent, and you can make faster and more informed decisions.

### Your key to greater success

With its modular and compact controllers, Phoenix Contact is always focusing on IT functions. As such, every controller has an integrated web server and supports numerous Ethernet-based communication protocols such as TCP/IP, HTTP, FTP or SNMP.

Together with Phoenix Contact, you can design automation systems in which all components are perfectly matched to one another and can be integrated with a high degree of flexibility, both horizontally and vertically. This allows you to achieve a fast and consistent information flow throughout your entire network: from the field installation to the controller and visualization, right through to the SAP world. Important data is always available at the right time and the right place – which means more communication and therefore more productivity.



## Contents

System overview	4
Programmable logic modules	6
Class 100 modular small-scale controllers	8
Function blocks	12
Class 300 modular small-scale controllers	14
Modular Axiocontrol controllers	16
Class 400 compact high-performance controllers	18
Software PLC	20
Technologies	
– PROFINET	22
– PROFICLOUD	24
– PROFI-safe	28
– Redundancy	30
– Proxies	32
Software	34
Software technology	42
Service and support	44
Technical data	46

# System overview:

## The right controller for every application

Phoenix Contact offers trend-setting and innovative controllers in numerous performance classes. All devices can be used easily with the PC Worx engineering software every step of the way. IT technology enables you to integrate all programmable logic controllers into networked systems without any problems.

### PLC logic

#### programmable logic modules

The compact PLC logic relay system offers cost-effective solutions for smaller project applications.

*More information from page 6 onwards*



### Class 100

#### modular small-scale controllers

Thanks to their modular structure, the class 100 controllers are particularly versatile – ideal for easy automation of small and medium-sized applications.

*More information from page 8 onwards*



### Class 1000

#### modular small-scale controllers

The class 1000 Axioccontrol controllers are fast, robust, and user-friendly. Together with the Axioline I/O systems, they are at the heart of a high-performance automation system.

*More information from page 16 onwards*



## Easy Automation

Automation does not have to be expensive or complicated. The Easy Automation system from Phoenix Contact is proof of that. Automate small to medium-sized applications in a cost-optimized and, above all, easy way. All components are perfectly coordinated.

- Ideal for smaller applications with low connectivity
- All components and software blocks are easy to handle, thanks to reduced complexity
- High system availability, thanks to consistent compatibility of components
- Can be flexibly extended with numerous I/Os and function modules for implementing your individual requirements

# High performance

Phoenix Contact's high-performance controllers reliably control demanding automation tasks in complex network structures:

- Maximum computing capacity and high data throughput
- Reliable automation, especially for high-end applications with high-performance safety and redundancy controllers
- Easy-to-use and universally applicable engineering software



## Class 3000 modular high-performance controllers

The class 3000 Axioccontrol controllers feature powerful technology in a particularly robust housing with excellent EMC properties.

*More information from  
page 16 onwards*

## Class 300 modular controllers

Class 300 controllers let you can reliably automate average to demanding applications.

*More information from  
page 14 onwards*



## Class 400 compact high-performance controllers

High-end class 400 controllers solve complex automation tasks. The range also includes a safety version and a PLC for PROFINET redundancy.

*More information from  
page 18 onwards*



## Software PLC

Extend your industrial PC with PC WORX RT BASIC or PC Worx SRT and transform it into a high-performance controller.

*More information from  
page 20 onwards*

## Simple engineering

- **PC Worx:** the consistent IEC-compliant engineering software for all Phoenix Contact controllers
- **PC WORX EXPRESS:** the free-of-charge little sister to PC Worx, for easy programming of small-scale controllers

*More information from page 34 onwards*



# Programmable logic modules: Extremely compact control and switching



## Stand-alone module

### Stand-alone module

Order No.: [2907445/2907443](#)

- Screw or push-in connection technology
- 16 I/Os, not expandable
- Connection to PC via micro USB socket
- Integrated realtime clock
- Accommodates external IFS-CONFSTICK memory module

Are you looking for a cost-effective controller solution for smaller applications but don't need all the functions of a full-fledged controller?

The modular design of PLC logic enables the combination of relay and analog modules with logic functions. Switch and control I/O signals in small applications using the compact stand-alone module. Thanks to the combination of a basic module and two extension modules, more complex tasks can also be performed. Logic+ lets you program your application intuitively – without any programming knowledge.

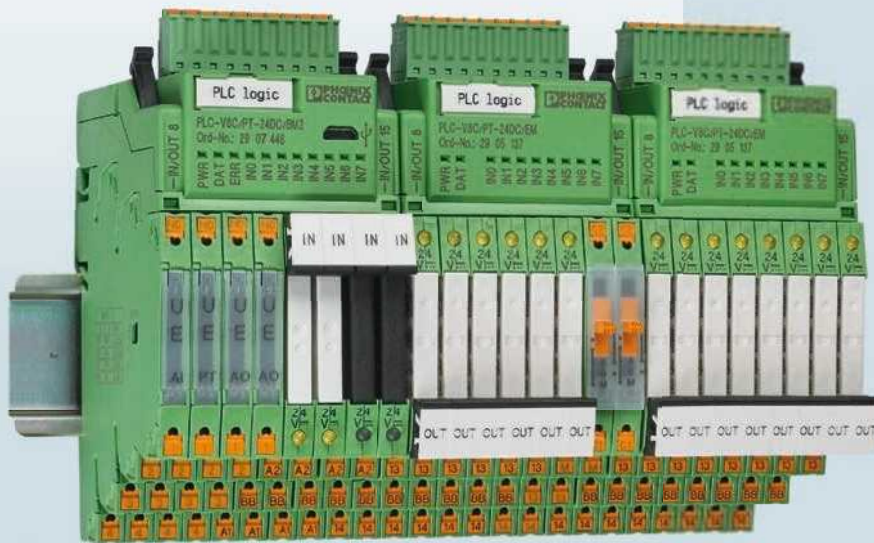

## Your advantages with the programmable logic modules:

- High availability, thanks to pluggable switching elements
- Diverse combination options, since each channel can be custom-equipped with relay or analog modules
- Efficient wiring, thanks to push-in connection technology and special versions for the sensor or actuator wiring
- Easy implementation of projects, thanks to intuitive software
- Wireless operation and monitoring by means of a Bluetooth adapter and PLC logic app



### Basic module

### Extension module

### PLC logic app

**Basic module**  
Order No: [2907447/2907446](#)

**Extension module**  
Order No.: [2903095/2905137](#)

**Flexible operation with the PLC logic app**

- Screw or push-in connection technology
- 16 I/Os, can be extended up to a maximum of 48 I/Os
- Connection to PC via micro USB socket
- Integrated realtime clock
- Accommodates external IFS-CONFSTICK memory module
- Optional connection to PROFIBUS-GATEWAY-IFS

- Screw or push-in connection technology
- 16 I/Os, for extending the basic module
- Connection of a maximum of two extension modules per basic module

Use the PLC logic app to adjust parameters easily and take advantage of the flexible operation and display. You only need one visualization device to monitor and operate multiple machines via a wireless connection. Read the status of inputs and outputs, apply changes, or respond quickly to malfunctions.

## Intuitive programming using LOGIC+

Logic+ is the intuitive software which allows you to implement your projects. Ladder (LD) and function block diagrams (FBD) can be created by selecting the relevant functions and their connection using drag & drop. In doing so, the following function blocks are available to the user:

- Basic functions: AND, OR, NOT, XOR
- Mathematical functions: add, divide, multiply, subtract, generate absolute value
- Positive and negative edge detection
- RS and SR flip-flops
- Switch-on and switch-off delay, pulse encoder, pulse stretching, weekly clock timer
- Up and down counter

- Analog and digital comparators
- Special functions, such as solar altitude calculations are available for download

The clear separation in the program editor, toolbox, hardware view and signaling window are especially user friendly. The programs created can be simulated offline on the PC and tested online during operation. Numerous examples of use make it easy to get familiarized with the software.



# Class 100 modular small-scale controllers: simply versatile

Modular programmable logic controllers from Phoenix Contact stand out for their high functional density and support all current standards such as Ethernet, mobile communication or fixed-line network.

Thanks to integrated Modbus/TCP, the controllers communicate with numerous fieldbus devices without any additional programming, both passively as a Modbus server as well as actively as a Modbus client. In addition, the parameterization memory can be expanded with an SD card.

Your advantage: You can quickly and easily integrate additional user libraries with function blocks.



## Most cost-effective PLC

**ILC 131 ETH**

Order No. [2700973](#)

- 192 kbyte program memory and 192 kbyte mass storage
- 8 kbyte retentive mass storage
- 1 INTERBUS interface and 1 Ethernet interface
- 8 direct inputs and 4 direct outputs
- I/O points: 2 kbit to 10 kbit
- Integrated web/FTP server
- OPC functionality
- Maritime approvals: LR, BV, ABS, RINA, BSH, GL



## Your advantages with the class 100 modular small-scale controllers:

- High processing speed thanks to the high-performance Altera NIOS II processor
- Maximum flexibility in I/O connectivity thanks to integrated fieldbus master and Modbus/TCP
- Expandable through the addition of functions with optional parameterization memory on an SD card
- Optimal communication with integrated, freely programmable web server
- Versatile use, as all common Ethernet protocols are supported
- Easy to integrate in existing PROFINET networks by means of PROFINET device functionality





## Standard PLC

## PLC with 2 Ethernet ports

## PLC with integrated FPU

### ILC 151 ETH Order No. 2700974

- 256 kbyte program memory and 256 kbyte mass storage
- 8 kbyte retentive mass storage
- 1 INTERBUS interface and 1 Ethernet interface
- 8 direct inputs and 4 direct outputs
- I/O points: 4 kbit to 16 kbit
- Integrated web/FTP server
- OPC functionality
- Maritime approvals: LR, BV, ABS, RINA, BSH, GL

### ILC 171 ETH 2TX Order No. 2700975

- 512 kbyte program memory and 512 kbyte mass storage
- 48 kbyte retentive mass storage
- 1 INTERBUS interface and 2 Ethernet interfaces
- 8 direct inputs and 4 direct outputs
- I/O points: 4 kbit to 36 kbit
- Integrated web/FTP server
- OPC functionality
- Maritime approvals: LR, BV, ABS, RINA, BSH, GL

### ILC 191 ETH 2TX Order No. 2700976

- 1 Mbyte program memory and 1 Mbyte mass storage
- 48 kbyte retentive mass storage
- Integrated FPU for fast floating-point arithmetic
- 1 INTERBUS interface and 2 Ethernet interfaces
- 8 direct inputs and 4 direct outputs
- I/O points: 4 kbit to 36 kbit
- Integrated web/FTP server
- OPC functionality
- Maritime approvals: LR, BV, ABS, RINA, BSH, GL



## PLC with modem

## PLC with extended temperature range

## Pre-assembled test structure

### ILC 151 GSM/GPRS Order No. 2700977

- Integrated GSM/GPRS modem
- 1 INTERBUS interface and 1 Ethernet interface
- 512 kbyte program memory and 512 kbyte mass storage
- 48 kbyte retentive mass storage
- 16 direct inputs and 4 direct outputs
- I/O points: 4 kbit to 16 kbit
- Integrated web/FTP server
- OPC functionality

### ILC 131 ETH/XC Order No. 2701034 ILC 151 ETH/XC Order No. 2701141

- Temperature range -40 °C ... +60 °C
- 192 kbyte (ILC 131 ETH/XC) and 256 kbyte (ILC 151 ETH/XC) program/mass storage
- 8 kbyte retentive mass storage
- 1 INTERBUS interface and 1 Ethernet interface
- 8 direct inputs and 4 direct outputs
- I/O points: 2 kbit/4 kbit to 10 kbit/16 kbit
- Integrated web/FTP server
- OPC functionality
- Maritime approvals: LR, BV, ABS, RINA, BSH, GL

### ILC 131 STARTERKIT Order No. 2701835

The ILC 131 starter kit provides an easy introduction to our controllers.

Components:

- 2-channel analog input terminal
- Potentiometer for analog value definition
- 8-fold switch strip for specifying digital signals
- CAT5 Ethernet cable and power supply unit
- CDs with example projects and documentation

# Class 100 modular small-scale controllers: versions for machine building

The ME variants of our modular controllers, developed for the requirements in machine building, are additions to the Easy Automation automation system. They are the ideal solution for controlling drives using step motor drivers or frequency inverters.

The controllers offer all the functions of ILC class 100 and come with pre-installed functions for machine building.

This means that various drive types and sensors can be connected without any additional external modules. Depending on the version, analog or incremental input channels can be used for position detection.

## Your advantages with the ME models:

- Ideal for machine building, thanks to specially tailored functions
- All tried-and-tested advantages of class 100
- Excellent price/performance ratio with high functional density
- Two-channel drive control without additional I/O components
- Flexible, thanks to the direct connection of step motor drives and frequency inverters
- Precise position detection with analog and incremental input channels
- Modbus/RTU library for the RS-485 interface
- Convenient implementation of process and reference procedures thanks to the Easy Motion library
- Wide compatibility thanks to function blocks in accordance with the PLCopen standard





## PLC for drive control

## PLC for drive control

## Minitouch

### ILC 191 ME/AN

Order No. 2700074

- 8 digital inputs and 4 digital outputs
- 2 analog inputs and 2 analog outputs
- RS-232 to PS/2
- RS-485/422
- 2-channel PWM function (5 V)
  - For the indirect control of step motors using the pulse/direction signal
  - Generates square waves with a controllable pulse duty factor and frequency
- 10 V reference voltage source

### ILC 191 ME/INC

Order No. 2700075

- 8 digital inputs and 4 digital outputs
- RS-232 to PS/2
- RS-485/422
- 2-channel PWM function (5 V)
  - For the indirect control of step motors using the pulse/direction signal
  - Generates square waves with a controllable pulse duty factor and frequency
- 2 fast counters (max. 200 kHz)
- 2 incremental encoder inputs

### TD 1030T

Order No. 2701257

- Cortex M3 processor with 120 MHz
- 7.1 cm (2.8") TFT touch display
- 2-bit color depth, 4 colors can be displayed
- 320 x 240 pixel (QVGA) resolution
- LED backlighting
- 512 kbyte Flash, 96 kbyte SRAM
- 1 x Ethernet (10/100 Mbps), RJ45
- Including Keil RTX (RTOS) and nano browser
- IP54 on the front, IP20 on the back
- Temperature range of 0°C ... +50°C

## Reliable and precise axis control

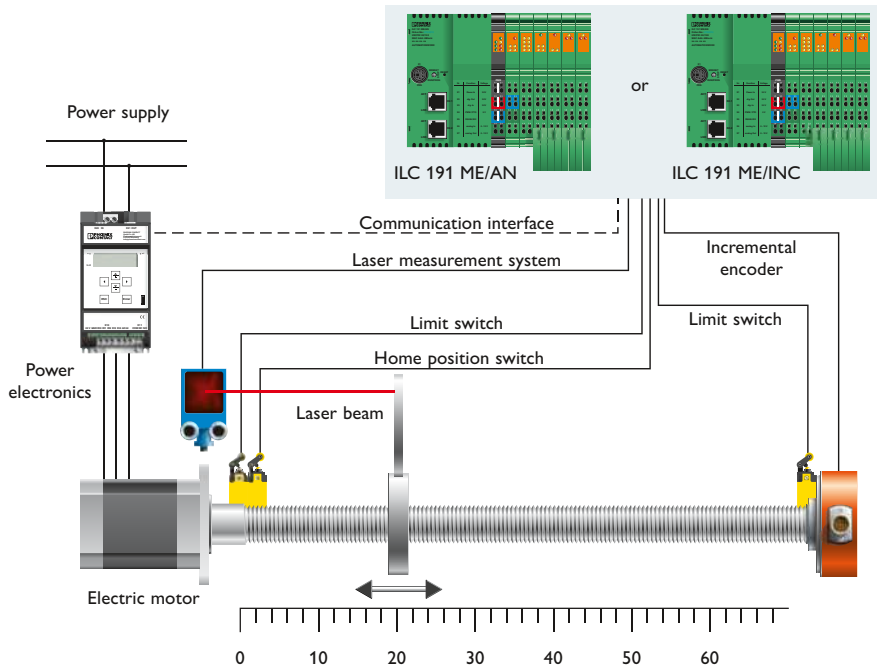

The ME versions of the modular small-scale controllers offer Ethernet, RS-485 or pulse/direction interfaces. This means that electric motors can be driven by frequency inverters or other power electronics. In addition, limit switches and home position switches are connected directly to the controller.

Analog inputs (ILC 191 ME/AN) are available for the position detection of a tool using a laser measuring system, for example. The ILC 191 ME/INC offers digital sensor inputs for incremental encoders.

# Function blocks: quick and easy controller expansion

Modular controllers from Phoenix Contact can be adapted to any requirement quickly and easily using SD cards and function blocks. This means that parameterization memories, licenses for function block libraries or completely tested applications can be installed at a later time, without the need for additional hardware.

Industry-specific function blocks are tailored to the individual requirements of a particular industry and offer considerable advantages when it comes to engineering.

You can use the SD FLASH 2GB Easy Safe to start up SafetyBridge applications, for instance, quickly and easily, without additional programming in PC Worx.

## Your advantages with function blocks:

- Individual expansion of the controller solution with complete and tested applications such as data logging or multiplexer functions
- Activation of libraries and function blocks via license keys
- Parameterization memory extensions for specific applications
- Uncomplicated device replacement by transferring the data via SD card



## Energy automation in accordance with IEC 61850

### SD FLASH 2GB 61850

Order No.: 2400435

### SD FLASH 2GB APPLIC A 61850

Order No.: 2400436

Software for efficient energy automation in accordance with the IEC 61850 standard for expanding the modular AXC 1050 controller.

- Transmit and receive GOOSE messages
- MMS communication
- Automatic time stamping
- Also with licence key for the function block library (APPLIC A only)





## Licence keys for functional expansion

### SD FLASH 2GB APPLIC A...

Order No.: 2701190

Flash memory card with license key for the function block libraries, e.g.:

- Data transfer between the controller and SQL database by means of SQL communication and Data Manipulation Language (DML)
- IT library with SMTP function, with DHCP client, DNS, and FTP client function



## Software for usage data acquisition

### SD FLASH 2GB EMLOG

Order No.: 2403484

Software for energy data acquisition using the modular ILC 191 ME/AN controller.

- Reading of measuring devices via pulses, analog values, M-bus, Modbus/RTU



## Multiplexer function for retrofitting

### SD FLASH 512MB MODULAR MUX

Order No.: 2701872

Software for setting up a multiplexer function with two ILC 171 ETH 2TX controllers.

- Easy configuration thanks to the small number of wire jumpers
- Wireless connection or connection via ethernet cable or network
- No programming necessary



## Small-scale safety controller

### SD FLASH 2GB EASY SAFE BASIC

Order No.: 2403297

### SD FLASH 2GB EASY SAFE PRO

Order No.: 2403298

You can use the application on the SD card and SafetyBridge modules to expand your ILC 151 ETH controller into a small-scale safety controller.

- SAFECNF is available for free for programming, no PC Worx necessary
- Simple, web-based configuration and commissioning
- Modbus and PROFINET connection as well as e-mail function (PRO version)

## Flexible and fast expansion via SD cards

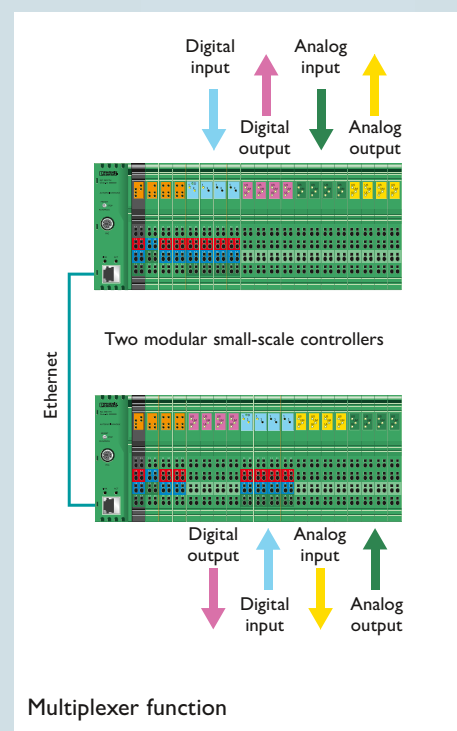
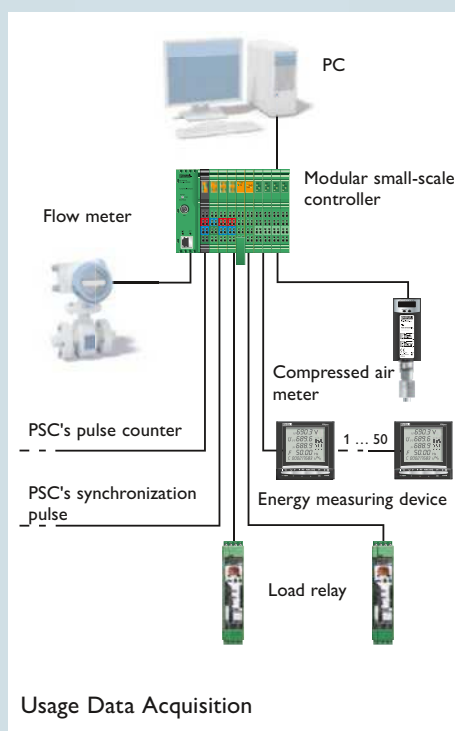

# Class 300 modular controllers: Flexible automation with PROFINET

The class 300 modular controllers provide optimum control for average to demanding automation tasks. Two Ethernet ports with an integrated switch facilitate flexible connection to a higher-level control room, a local operating station or I/O modules. All the information that is needed, for example when starting up the controller following a device replacement, is stored on a memory card.

## Your advantages with the class 300 modular controllers:

- High level of flexibility, thanks to expansion with numerous I/O modules
- PROFINET controller and device functionality for consistent PROFINET communication
- Support of IT standards such as FTP, HTTP or SNMP, enabling easy integration into existing networks
- Intuitive programming with PC Worx





## Standard PLC

## Communicative PLC

## Powerful PLC

### ILC 350 PN

Order No. [2876928](#)

- PXA 255 processor
- 1 Mbyte program memory
- 2 Mbyte mass storage
- 64 kbyte retentive mass storage
- I/O points: 8 kbit to 210 kbit
- One Ethernet/PROFINET (10/100) interface and one INTERBUS interface (master)
- 12 direct inputs and 4 direct outputs

### ILC 370 PN 2TX-IB/M

Order No.: [2985576](#)

- PXA 255 processor
- 2 Mbyte program memory
- 4 Mbyte mass storage
- 96 kbyte retentive mass storage
- I/O points: 8 kbit to 210 kbit
- Two Ethernet/PROFINET (10/100) interfaces and one INTERBUS interface (master/slave)
- 12 direct inputs and 4 direct outputs
- Maritime approvals: LR, BV, ABS, RINA, BSH, GL

### ILC 390 PN 2TX-IB

Order No. [2985314](#)

- PXS 270 processor
- 2 Mbyte program memory
- 4 Mbyte mass storage
- 96 kbyte retentive mass storage
- I/O points: 8 kbit to 210 kbit
- Two Ethernet/PROFINET (10/100) interfaces and one INTERBUS interface (master/slave)
- 12 direct inputs and 4 direct outputs



### Controlling water supply and disposal: Lügde, Germany

The processes of water supply and disposal in the town of Lügde are controlled and managed by an ILC 350 type Phoenix Contact controller. Communication with higher and lower-level systems is established over an Ethernet interface. This interface offers several communication options, such as OPC, Modbus, and other IP-based protocols.



### Automation at airports: FMT Aircraft Gate Support Systems AB

An ILC 350 PN modular controller ensures the flexible and safe transfer of passengers on the fully-automated passenger boarding bridge constructed by the Swedish manufacturer FMT. Position data is transmitted simultaneously from the central PROFINET controller to up to four axes of the gate system for the docking procedure, depending on the type of aircraft. This ensures the fastest possible turnaround of passengers.

# Modular Axioccontrol controllers: Fast, robust, and easy

Modular Axioccontrol controllers are consistently designed for maximum performance, easy handling and use in harsh industrial environments. A particularly robust housing and excellent EMC properties provide the basis for this. Together with the Axioline F I/O system from Phoenix Contact, Axioccontrol offers maximum speed thanks to direct bus connection.

## Your advantages with Axioccontrol controllers:

- Reliable, thanks to robust housing and a high level of resistance to EMI
- Increased safety thanks to an integrated uninterruptible power supply
- Save wiring time with push-in connection technology
- Fast access, e.g. for diagnostics, thanks to a USB connection
- More parameterization memory, thanks to optional SD card



## Reliable control in harsh environments:

The Axioccontrol series controllers feature particularly robust housing and electronics. XC versions are also available for deployment in extreme cold. In addition, the devices are suitable for buildings and environments susceptible to interference, thanks to excellent EMC properties.





### Small-scale controller

### Small-scale controller (extended temp. range)

### High-performance controller

#### AXC 1050

Order No. 2700988

- Altera NIOS II processor
- 1 Mbyte program memory
- 2 Mbyte mass storage
- 48 kbyte retentive mass storage
- I/O points: 4 kbit to 36 kbit
- Integrated FPU for floating point arithmetic
- 2 Ethernet and 1 Axioline F interface
- Maritime approvals: LR, BV, ABS, RINA, BSH, GL

#### AXC 1050 XC

Order No. 2701295

- Altera NIOS II processor
- 1 Mbyte program memory
- 2 Mbyte mass storage
- 48 kbyte retentive mass storage
- I/O points: 4 kbit to 36 kbit
- Integrated FPU for floating point arithmetic
- 2 Ethernet and 1 Axioline F interface
- Temperature range: -40°C to +70°C
- Maritime approvals: LR, BV, ABS, RINA, BSH, GL

#### AXC 3050

Order No. 2700989

- Intel® Atom™ E660
- 4 Mbyte program memory
- 8 Mbyte mass storage
- 128 kbyte non-volatile mass storage
- I/O points: 8 kbit to 512 kbit
- 3 separate Ethernet/PROFINET interfaces and 1 Axioline F interface
- Maritime approvals: LR, BV, ABS, RINA, BSH, GL

## Fast, robust, and easy at all times – Axiocontrol

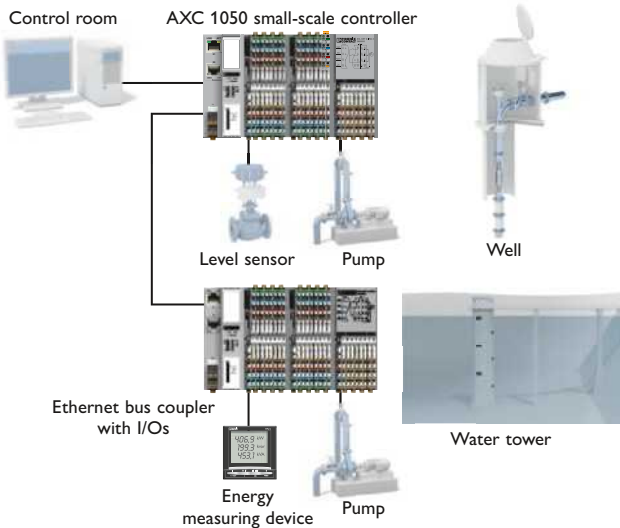

The AXC 1050 modular controller is ideal for distributed applications, such as water and wastewater treatment. Thanks to an integrated UPS, you increase the availability of your system. This means a message can be used to notify the control center after a voltage drop, for example.

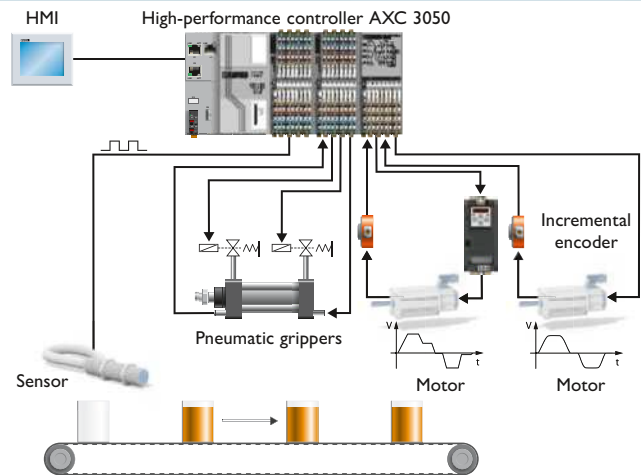

Medium-sized and large systems can be controlled in machine building using the modular AXC 3050 controller. Thanks to functions such as fast counters, high-performance processors, and direct I/O connection to Axioline F, you can perform demanding tasks, such as rotation speed and machine cycle monitoring.

# Class 400 compact high-performance controllers: for maximum performance

If your application places any special demands on controller performance, the class 400 compact controllers are just the right alternative. They combine high performance with an attractive price. An integrated diagnostics display provides information relevant to the process and event-controlled error messages directly on-site. The coded key switch protects against unauthorized access. If you replace a device, the flash memory of the faulty controller simply needs to be plugged into the new device. It doesn't get any easier.

## Your advantages with the class 400 high-performance controllers:

- Integration of safety functions up to SIL 3 into existing systems using PROFIsafe technology
- Maximum availability guaranteed in critical processes, thanks to PROFINET-based controller redundancy
- High-resolution display with plain text messages for local diagnostics





## Basic PLC

## Safety controller

## Redundant PROFINET PLC

**RFC 470 PN 3TX** Order No. [2916600](#)

- Intel® Celeron® 927UE processor
- 8 Mbyte program memory
- 16 Mbyte mass storage
- 240 kbyte retentive mass storage
- 2 independent network interfaces
- INTERBUS master
- PROFINET controller and device
- 5 direct inputs and 3 direct outputs
- I/O points: 8 kbit to 512 kbit

**RFC 470S PN 3TX** Order No. [2916794](#)

- Intel® Celeron® 927UE processor
- 2 independent network interfaces
- PROFINET controller with PROFIsafe function
- PROFINET device
- INTERBUS master
- Programming of safe programming logic using the Safetyprog software
- I/O points: 8 kbit to 512 kbit

*More information from page 28 onwards*

**RFC 460R PN 3TX** Order No. [2700784](#)

- High availability thanks to integrated PROFINET-based redundancy function
- Intel® Celeron® M ULV 423 processor
- 8 Mbyte program memory
- 16 Mbyte mass storage
- 120 kbyte retentive mass storage
- 2 independent network interfaces
- PROFINET controller
- I/O points: max. 512 kbit

*More information from page 30 onwards*



### Automotive production: AUDI AG, Brussels

As a longstanding system partner of AUDI AG, Phoenix Contact has provided the Brussels factory with control technology for purposes including body construction and the associated conveying technology. For a controller, Audi Brussels chose a high-performance RFC which monitors up to 15 HMI devices via a standardized OPC data connection. The high-performance controller includes PROFINET, INTERBUS and Ethernet interfaces.



### Wind farm management: Nordex, Susurluk (Turkey)

For wind farm regulation and system control for its wind farm in Turkey, Nordex uses RFC safety controllers from Phoenix Contact. These controllers combine an operation controller and a safety PLC in a single product. The controller records data such as wind speed in order to set an optimal angle of the rotor blade. As a result, a single wind turbine achieves a maximum electrical output of 2.5 MW.

# Software PLC: From industrial PC to controller

Industrial PCs for visualizing and operating processes are often only utilized to a limited extent. Make use of the available resources and transform your industrial PC into a full-fledged controller as well. PC WORX SRT has low hardware profile, allowing it to be installed on almost all Windows PCs – making it ideal for small applications.

PC WORX RT BASIC offers the high performance expected from a conventional PLC and is suitable for sophisticated tasks.

## Your advantages with the RT BASIC software PLC:

- Crash-proof operating system
- Optimum connection thanks to integrated web server and support for all common IT standards
- AX OPC server support
- Programming, visualization, and control can be performed on the same hardware
- Programming with PC Worx
- Easy communication via PROFINET or Modbus using the PC's Ethernet interface



## Machine building and systems manufacturing: the IPC as the central unit of the system

The industrial PC is transformed into the central control unit, operator interface, and visualization unit of your system. As the separate controller hardware is no longer required, wiring effort and control cabinet volumes are significantly reduced. PC WORX RT BASIC therefore offers a cost-optimized turn-key solution.



## Software PLC without real-time extension

## Software PLC with real-time extension

**PC WORX SRT** Order No. 2701680

- Software PLC for installation on almost any Windows or industrial PC
- 1 Mbyte program memory
- 1 Mbyte mass storage
- 48 kbyte retentive mass storage
- Communication via PROFINET, Modbus/TCP and serial RS-232/422/485 interface
- I/O points: 8 kbit to 28 kbit

**PC WORX RT BASIC** Order No. 2700291

- Realtime-capable software PLC for installation on an industrial PC
- 8 Mbyte program memory
- 16 Mbyte mass storage
- 240 kByte retentive mass storage
- Communication via PROFINET, INTERBUS or Modbus
- I/O points: 8 kbit to 512 kbit

## Installation transforms the industrial PC into a controller

The installation of the PC WORX RT BASIC software PLC transforms the industrial PC into a full-fledged controller in just a few minutes. A real-time extension is added to the standard operating system in the process. The actual software PLC then operates in this real-time environment. The extension shields the control application from the Windows environment in such a way that the integrity and the deterministic behavior of the software PLC are ensured.

With a multi-core processor, one processor core is used exclusively for the software PLC. This offers additional protection for the control application. Additional hardware, such as Ethernet controllers and part of the RAM, is also available exclusively to the controller.

During the installation of PC WORX RT BASIC, an additional virtual Ethernet interface is created. Data can be exchanged over TCP/IP and OPC by means of the

internal connection between Windows and the controller.

The software PLC supports the tried and tested INTERBUS system and the Ethernet-based PROFINET and Modbus/TCP. INTERBUS devices are connected by means of an INTERBUS PCI card installed in the industrial PC. PC WORX RT BASIC

uses a standard Ethernet interface from the industrial PC to communicate with the installed I/O modules using PROFINET.



# PROFINET: The Industrial Ethernet standard

Products, industry-specific functions, and block libraries plus coordinated software provide the basis for industry solutions from Phoenix Contact.

With our expert know-how for the relevant industry, Phoenix Contact provides support for stand-alone solutions as well as complex industrial systems.

## Products

### Everything from a single source

An extensive product portfolio offers proven and certified hardware and software for all aspects of PROFINET technology.

## Software

### Engineering is key

Phoenix Contact software and hardware are optimally coordinated. When used together, they offer solutions for all levels of an automation task while simultaneously reducing the amount of engineering involved.



## The PROFINET starter kit

### AXC 1050 PN starter kit

Find out how easily you can create and start up PROFINET networks by using our products. Phoenix Contact provides you with a PROFINET starter kit with all the necessary components for creating a test application.

#### Your advantages:

- Quick entry into automation with PROFINET, thanks to step-by-step instructions for the test setup
- Design with state-of-the-art automation station based on Axiocontrol and Axioline components



## Solutions

### Tailored to your industry

Application-specific solution packages are created in cooperation with our customers and partners. You can start benefiting from the expertise today, as it provides the foundation for new innovations.

## Industries

### Command of processes

As an automation specialist with extensive knowledge of your industry, we integrate individual industry solutions based on PROFINET and merge them to form complete processes. Phoenix Contact provides optimum support for end users as well as system integrators.

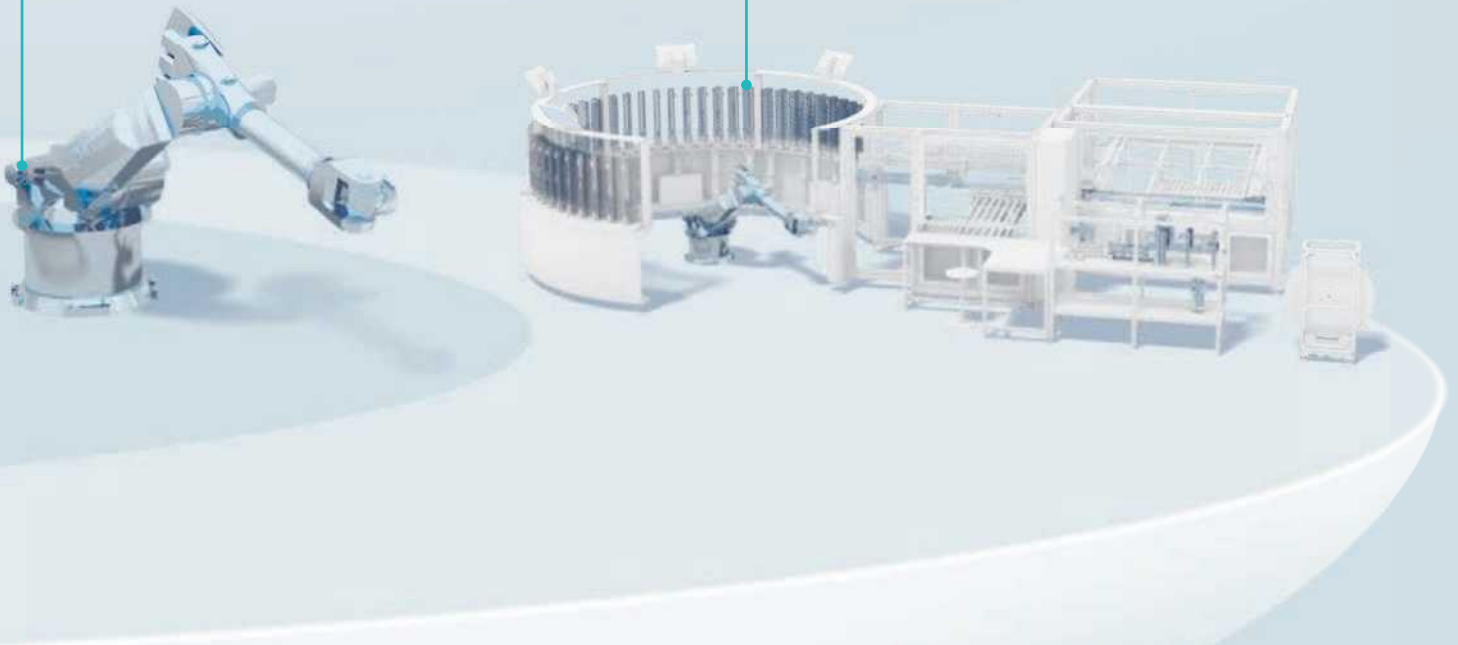

# PROFICLOUD: Professional cloud solutions for industry

The cloud represents digital and Internet-based processes. It also networks products, devices, people and companies. The Proficloud from Phoenix Contact provides you with professional, integrated cloud solutions for your automation. For example, thanks to Proficloud, distributed systems communicate directly and securely over the Internet based on the tried and tested PROFINET standard.

Make the right decisions today for your future and come along with us into the world of the Proficloud.

## Your advantages:

- The PROFINET network can be extended to include cloud services, without requiring any further specialist knowledge
- Maximum flexibility thanks to automation across borders from any location over the Internet
- Easy engineering because distributed devices and cloud services appear in the local PROFINET network
- Efficient automation thanks to preconfigured and preprogrammed Proficloud products
- Secure communication, thanks to TLS encryption





# Secure communication across different locations

Proficloud extends the PROFINET communication standard with the unlimited possibilities of the Internet, thereby simplifying distributed communication significantly.

Network devices – whether they are distributed on a local, regional or global scale – and even information from the Internet can be added easily and securely from the Proficloud to the local PROFINET

network. This opens up numerous new possibilities for automation solutions based on PROFINET.

Integrate information from PROFICLOUD services into your application or intelligently outsource tasks that require considerable processor power to central processing units in the Proficloud. Using the Software Development Kit (SDK), you can develop your own applications with

ease. The TLS (Transport Layer Security) encryption protocol ensures that your data remains secure.



10  
00  
11  
01

10  
00  
11  
01

10  
00  
11  
01

10  
00  
11  
01

10  
00  
11  
01

10  
00  
11  
01



10  
00  
11  
01

10  
00  
11  
01

10  
00  
11  
01

10  
00  
11  
01

10  
00  
11  
01

10  
00  
11  
01



# PROFICLOUD: easy networking and automation across borders

Use Proficloud to integrate distributed automation devices or cloud services into your local PROFINET network over the Internet – without any additional programming. This allows you to communicate securely and across all locations.

Professional cloud solutions from Phoenix Contact provide you with significant advantages for the industrial production of tomorrow.

## PROFINET and the cloud

Proficloud is an easy and inexpensive cloud platform. The Proficloud and the associated components enable you to extend your PROFINET network in no time at all.

The services from Phoenix Contact include the provision of the Proficloud, the necessary components and cloud services, as well as secure data transmission.

## Technical structure: PROFINET and the cloud

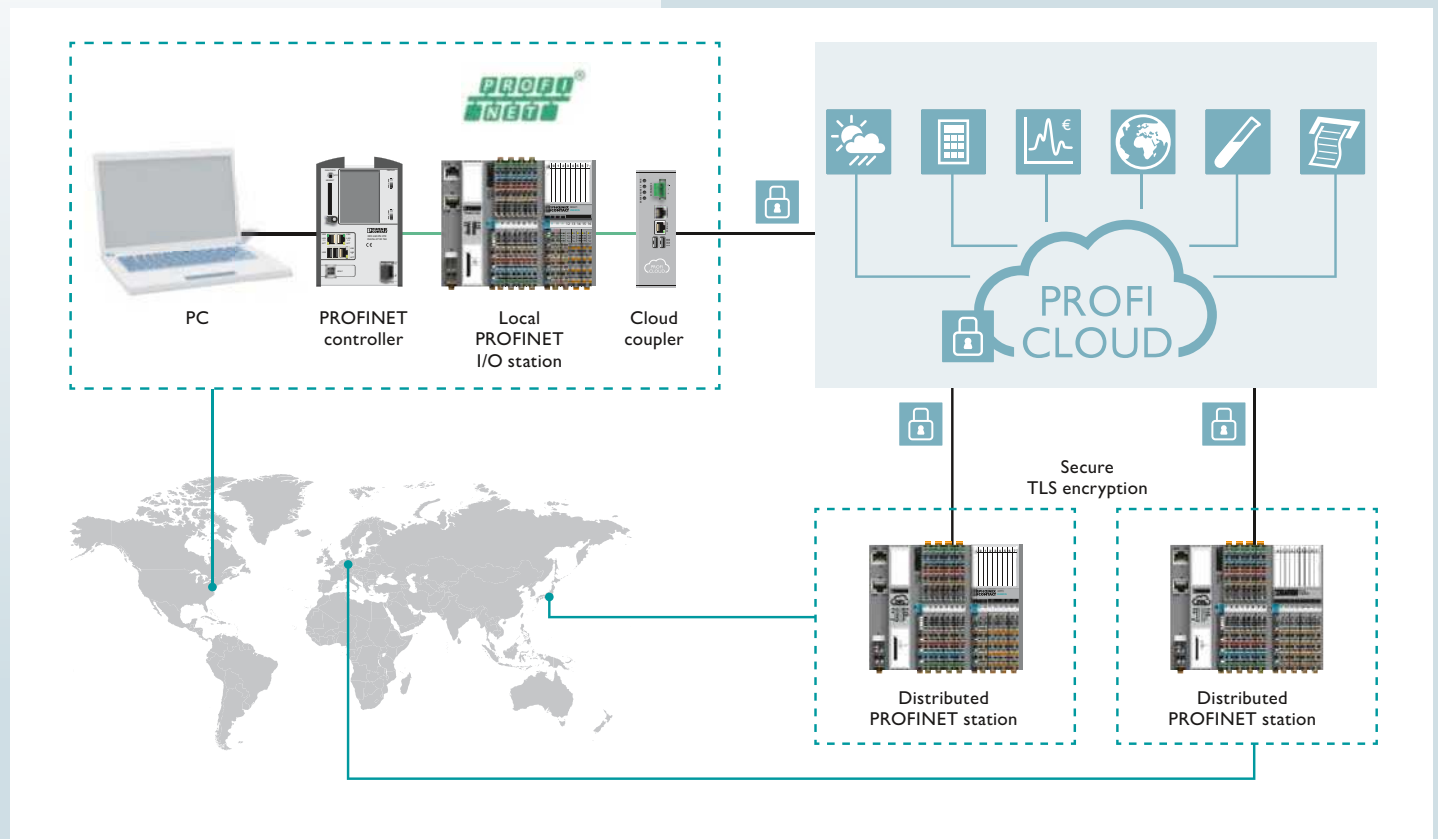

The cloud system for PROFINET for worldwide industrial communication consists of a Proficloud coupler, Proficloud controller,

Proficloud license and Proficloud services from Phoenix Contact.



### Local PROFICLOUD coupler

The coupler securely connects the local PROFINET network to the Proficloud over the Internet, also enabling the use of cloud services in PROFINET. Furthermore, the coupler protects the local PROFINET network against unauthorized access from the Internet by means of two independent network interfaces.

### Distributed Proficloud controller

The distributed controller connects to the Proficloud over the Internet. It now appears like a local device in the PROFINET network and can be used immediately without any further configuration or programming. The I/O components connected to the distributed controller are started up automatically. A separate application program can also be processed locally.

### Proficloud license Proficloud services

To use the Proficloud, activate your license in the cloud application. Integrate information from the Internet into your PROFINET application using the Proficloud.

You can also access and archive data or perform complex calculations in the Proficloud. The possibilities are virtually endless.

The Proficloud devices only use an outgoing connection, which means that unauthorized access to the local PROFINET network from the Internet is not possible.

In addition to the Proficloud services from Phoenix Contact, you can also create your own services thanks to the Software Development Kit (SDK).

### Products: Cloud system for PROFINET

Designation	Order No.
Local Proficloud coupler: CLOUD COULPER-PRO	2402990
Distributed Proficloud controller: AXC CLOUD PRO	2402985
Proficloud licenses: Cloud Credit 10/5/2/1	2402986 / 2402987 / 2402988 / 2402989
Proficloud service: Cloud Service / Weather	2403325
Proficloud service: Cloud Service / Calc	2403326
Proficloud service: Cloud Service / System coupler	2404449
Proficloud SDK: Cloud SDK4j	2404475

# PROFIsafe: Safety at the highest level

A wide range of safety functions, high numbers of I/Os, and large networks – be on the safe side even in complex automation systems with high-performance safety components from Phoenix Contact.

Reliably integrate functional safety into PROFINET networks. You can use our programmable safety controllers in both complex safety applications and standard applications. The PROFIsafe gateway enables safe communication between two PROFINET systems. Our safety-related I/O modules impress thanks to their flexible use.



## Safety controller

**RFC 470S PN 3TX** Order No. [2916794](#)

- 2 independent network interfaces
- PROFINET controller with PROFIsafe function
- PROFINET device
- INTERBUS master
- Programming of safe programming logic using the SafetyProg software
- I/O points: 8 kbit to 512 kbit



## Our products support the following safety functions within a PROFIsafe system:

- Up to SIL 3 according to EN 61508 and EN IEC 62061
- Up to PL e according to EN ISO 13849-1



## Safe analog value processing

## Safe PROFINET gateway

## PROFIsafe I/O module

**Safe AI** Order No. 2400057

Solution package for safe software-based analog value processing, without safe I/O modules.

- Safe analog value processing of up to 7 analog input signals
- Safety up to SIL 3 and PL e
- TÜV-certified
- Included in the package: initial application consultation by phone, license key for function block including user documentation and consultation with Competence Center Safety

**FL PN/PN SDIO-2TX/2TX** Order No.: 2700651

- Industrial gateway for connecting 2 secure PROFINET systems
- Coupling of safe and standard I/O data
- Redundant power supply
- Controller independent

**AXL F PSDI8/4 1F** Order No.: 2701559

**AXL F PSDO8/3 1F** Order No.: 2701560

**IB IL 24 PSDI 8-PAC** Order No.: 2985688

**IB IL 24 PSDI 16-PAC** Order No.: 2700994

**IB IL 24 PSDO 8-PAC** Order No.: 2985631

**IB IL 24 PSDO 4/4-PAC** Order No.: 2916493

**IB IL 24 PSDOR 4-PAC** Order No.: 2985864

Order No.: 2985864

- Depending on the PROFIsafe safety controller used, safety-related I/O modules can be used in PROFIBUS or PROFINET networks
- PROFIsafe modules from the Axioline F or Inline IP20 I/O range are available

## PROFIsafe: working across different networks

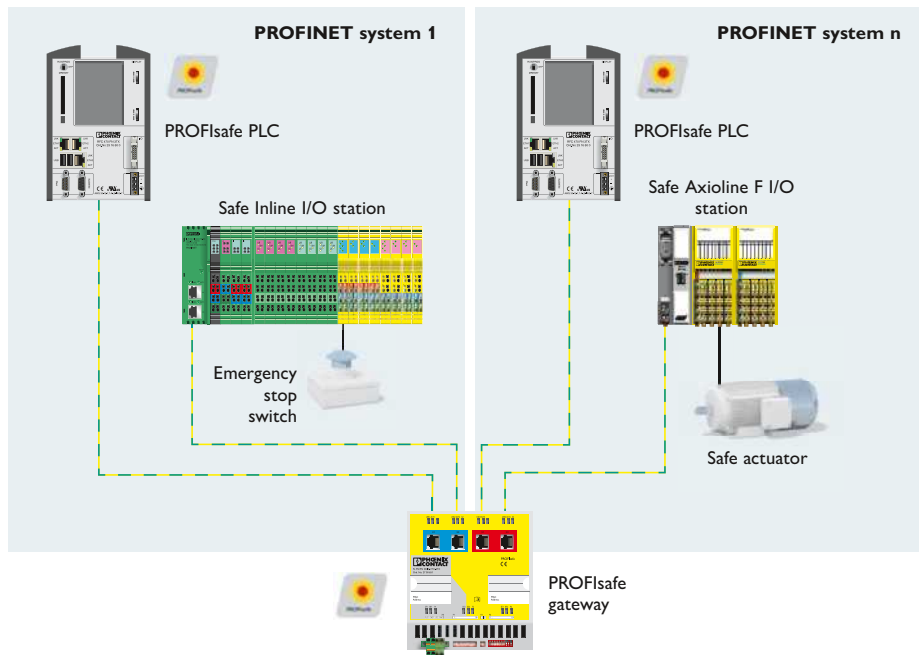

### PROFIsafe: consistent communication across network boundaries

The safe PROFINET gateway enables safe communication between two PROFIsafe I/O devices. Standard I/O process data is transmitted from one PROFIsafe system to another via PROFINET and safe I/O process data is transmitted via PROFIsafe.

The safe PROFINET gateway thereby implements system-wide and manufacturer-independent functional safety, such as emergency stop concepts.

# Redundant controllers: Systems for maximum availability

Increase your system availability with redundant control systems from Phoenix Contact. You can reduce downtimes, work cost-effectively, and also avoid potential hazards, e.g. in tunnels or at airports. Redundant control means that if one controller fails, the other takes over immediately, ensuring uninterrupted operation. The RFC 460R controllers are based on PROFINET and establish the redundant system automatically thanks to AutoSync technology. A unique feature is that when a controller is replaced, operation is not interrupted.

## Your advantages with redundant controllers:

- Easy startup and automatic configuration of all redundancy functions thanks to AutoSync Technology
- Optimum device integration thanks to PROFINET standards
- A distance of up to 80 km between the controllers using FO transmission; cost-optimized thanks to plug-in SFP modules
- Uninterrupted process during maintenance or when a controller is replaced
- Uninterrupted visualization thanks to redundancy-capable OPC server





## Redundant PROFINET PLC

## Switch

## Redundancy module

**RFC 460R PN 3TX** Order No. [2700784](#)

- High availability thanks to integrated PROFINET-based redundancy function
- Intel® Celeron® M ULV 423 processor
- 8 Mbyte program memory
- 16 Mbyte mass storage
- 120 kbyte retentive mass storage
- 2 independent network interfaces
- I/O points: max. 512 kbit

**FL SWITCH SMN 8TX-PN**

Order No. [2989501](#)

**FL SWITCH SMCS 8TX-PN**

Order No.: [2989103](#)

**FL SWITCH SMCS 6 .../2SFP**

Order No. [2891479](#); Order No. [2989323](#)

**FL SWITCH SMCS 8 ...**

Order No. [2891123](#); Order No. [2989226](#)

**FL SWITCH SMCS 16TX; 14TX/2FX**

Order No. [2700996](#); Order No. [2700997](#)

- PROFINET device
- MRP client and optional master function via FL MEM PLUG MRM
- Preconfigured versions for PROFINET

**QUINT ORING**

Order No.: [2320173](#)

- Active redundancy module with auto current balancing
- Decouples, monitors, and regulates the redundant power supply system

**QUINT DIODE**

Order No.: [2907719](#)

**TRIO DIODE**

Order No.: [2866514](#)

**UNO DIODE**

Order No.: [2905489](#)

**STEP DIODE**

Order No.: [2868606](#)

- Diode module
- Decouples and monitors the output voltage of the power supply



## AutoSync technology

AutoSync technology configures all redundancy functions automatically. The pair of controllers is only programmed on one controller and IP address. Data is transmitted automatically to the second device. If required, the pair of controllers can be visualized redundantly with just one OPC server. The fiber optics between the controllers can be up to 80 km long, perfect for transportation infrastructure, pipelines, and wind farms.

## Redundant control system for fault tolerance

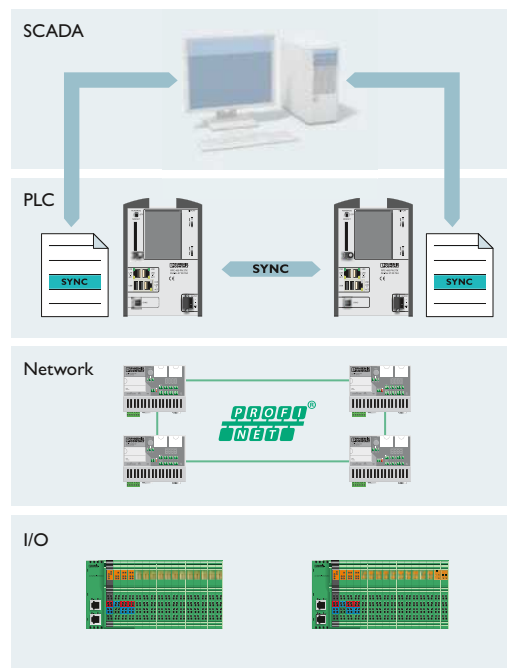

A redundant control system consists of various levels. The most important level is the control level, which has access to the process. Here, two compact controllers are synchronized in such a way that one of them always controls the process.

The OPC server ensures that the control level is always provided with data from the controller that is executing the process.

The I/O components are connected by PROFINET for standardized usage of network redundancy protocols. In almost all cases, these require a ring topology.

# Proxies: Integrating INTERBUS and PROFIBUS systems into PROFINET solutions

PROFINET is characterized by its subsystems which can be integrated into a consistent communication and diagnostics concept via a proxy. Based on the standardized PROFINET specification, the user can access all field devices. Duplicate configuration or addressing on the controller and proxy side is not required. Data exchange, diagnostics, and parameterization of the proxy are carried out via the PROFINET protocol. Older systems or subsegments, in which Ethernet communication is not advantageous, can be integrated into the PROFINET network without any loss of information.

## Your advantages:

- Configure or parameterize multiple networks and subsegments consistently
- Easy system modernization with transparent communication
- Versatile diagnostics, thanks to topology detection
- Manufacturer-independent diagnostics concepts
- Fast device replacement with optional CF card as parameterization memory
- PROFINET update rates up to 1 ms



## Automobile production: cost-effective technology combination

An example of proxy technology use is robotic applications used in automotive production. While communication within robotic cells is implemented using INTERBUS, the control cabinets are networked using PROFINET.





## INTERBUS to PROFINET

## INTERBUS to PROFINET with FO interfaces

## PROFIBUS to PROFINET

**FL NP PND-4TX IB** Order No. 2985974

Full-fledged INTERBUS master as a PROFINET proxy.

- PROFINET RT device (based on ERTEC 400) according to performance class B
- MRP client redundancy function
- 4-port switch (10/100 Mbps), RJ45 for line or star topology
- INTERBUS master for up to 512 devices
- Supports transmission speeds of 500 Kbps and 2 Mbps

**FL NP PND-4TX IB-LK**

Order No. 2985929

Full-fledged INTERBUS master as a PROFINET proxy.

- PROFINET RT device (based on ERTEC 400) according to performance class B
- MRP client redundancy function
- 4-port switch (10/100 Mbps), RJ45 for line or star topology
- INTERBUS master for up to 512 devices with remote bus interface in optically regulated fiber optic path
- Supports transmission speeds of 500 Kbps and 2 Mbps

**FL NP PND-4TX PB** Order No. 2985071

Full-fledged PROFIBUS master as a PROFINET proxy.

- PROFINET RT device, based on ERTEC 400, update rate 1 ms, minimum.
- 4-port switch (10/100 Mbps), RJ45
- Can only be integrated with PC Worx-based controllers
- PROFIBUS class 2 master with DP-V1 functionality
- Maximum of 126 PROFIBUS devices
- Transmission speed of up to 12 Mbps supported

## Connecting different networks

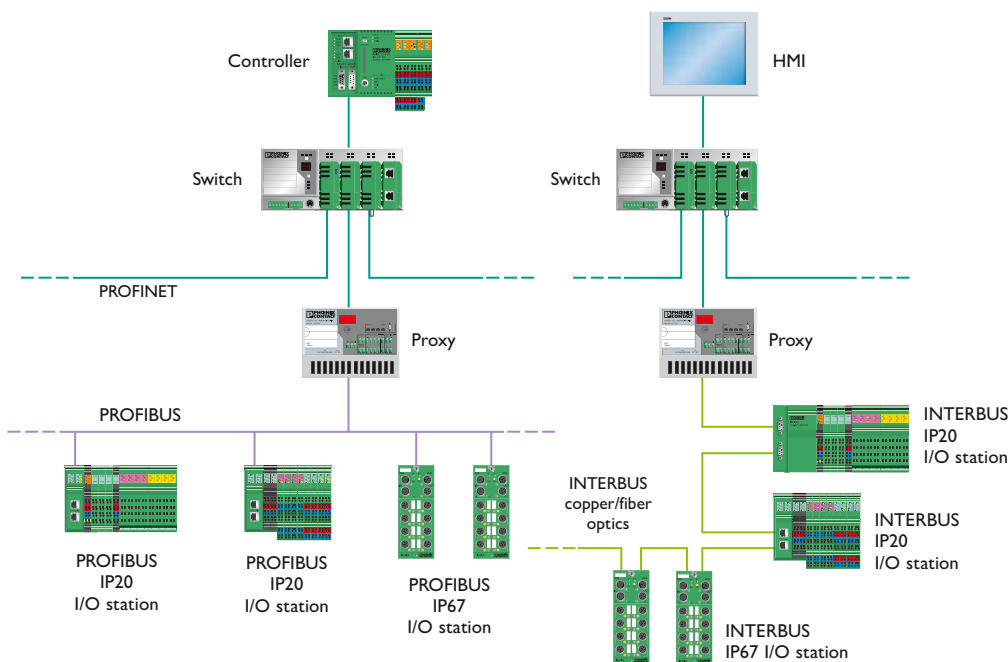

Conveniently connect your INTERBUS and PROFIBUS networks to the PROFINET using a proxy.

Alongside the standard version, a proxy with a fiber optic interface is also available for the INTERBUS range, especially for connecting to an INTERBUS line.

# Software: Solutions for all engineering phases

Software is the key to more efficient automation. Phoenix Contact offers software from configuration to system operation. All products interact perfectly and impress with their innovative functions and intuitive, user-friendly operation. Software tools and libraries, as well as interfaces and drivers are your efficient, multi-functional tool for all automation tasks.

## From planning ...

**Simulation/  
planning**

**Parameterization/  
configuration**

### **CLIP PROJECT**

Planning and Marking Software

### **CONFIG+**

INTERBUS Network Configuration

### **FL WST BASIC**

Wireless Simulation

### **SAFECONF**

Safety Configuration

### **PROJECT+**

I/O Project Planning

You can find detailed information about these products on the following pages.



### **Your advantages with automation software from Phoenix Contact:**

- Minimal engineering expense, thanks to interdependent software tools
- Fast startup, thanks to simulation and diagnostics
- High system availability, thanks to fast troubleshooting with effective diagnostic tools
- Can be used universally, thanks to software libraries for various industries

... to programming ...

... through to system service

## Programming

### LOGIC+

Compact Controller Programming

### PC WORX

PLC Programming

### PC WORX EXPRESS

Compact Controller Programming

### SAFETYPROG

Safety Programming

## Visualization

### VISU+

SCADA Visualization

### VISU+ Express

HMI Visualization

### WEBVISIT

Web Visualization

## System operation

### Connect+

Application start-up

### DIAG+

Network Diagnostic

### DIAG+ NETSCAN

Automatic INTERBUS Diagnostic

### PC WORX UA SERVER

Communication Interface

### STARTUP+

Wiring Check for Axioline

## Engineering workflow

### Software e-learning

With the help of short videos, you can learn how to set up Phoenix Contact software quickly and easily. The software tutorials show you the programming essentials in a clear and easily understandable manner.

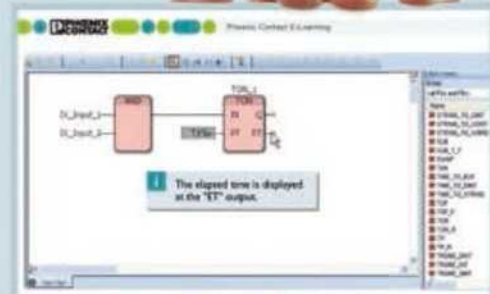

All videos can be found on our website in the Service and Support area

# Software: Tailored programming of automation systems

From clear tasks with modular small-scale controllers to complex system automation with high-end controllers: you'll find the right programming software for your application here. All Phoenix Contact controllers can be programmed throughout with PC Worx software. It combines programming in accordance with IEC 61131, fieldbus configuration and system diagnostics. For a fast introduction to automation with small-scale controllers, we also offer PC Worx EXPRESS programming software free of charge.

## PC WORX PLC Programming

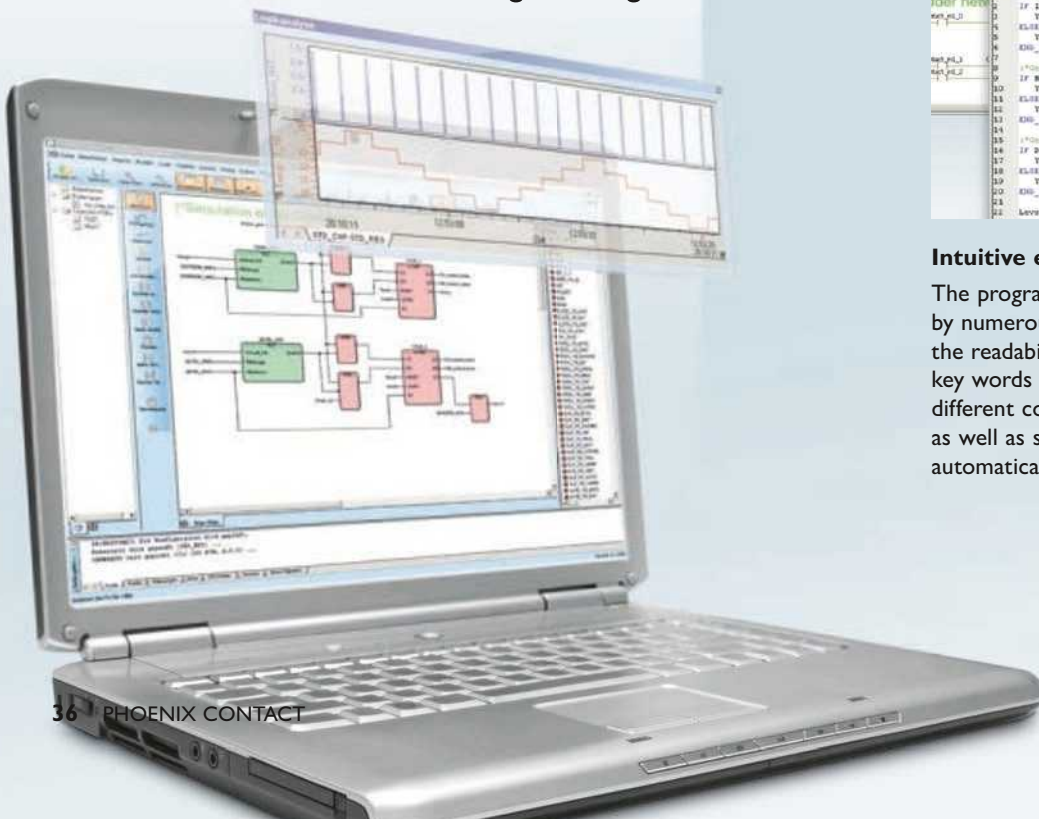

### Your advantages with PC Worx:

- Standardized controller programming thanks to support for all IEC 61131-3 languages
- User-friendly device handling, thanks to integrated PROFINET, PROFIBUS, INTERBUS, and Modbus/TCP configuration and addressing
- Easy source code editing, thanks to autocomplete with IntelliSense
- Reduced startup times, thanks to comprehensive debug mechanisms
- Test your program without hardware controllers, thanks to integrated simulation environment

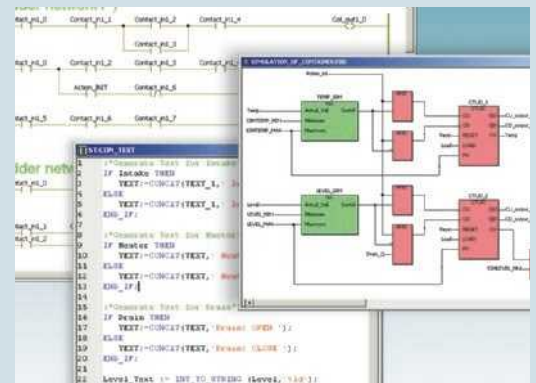

### Intuitive editors

The programming procedure in PC Worx is simplified by numerous editors. Syntax highlighting improves the readability of commands and variables, so that key words can also be displayed more clearly with different coloring. IntelliSense fills in variable names as well as structural and function block elements automatically.



## PLC programming

## Programming small-scale controllers

### PC WORX

- **DEMO** Order No. [2985725](#)
- **BASIC LIC** Order No. [2985275](#)
- **PRO LIC** Order No. [2985385](#)
- Programming of Phoenix Contact controllers
- Network configuration and diagnostics
- Numerous programming languages supported: IL, FBD, LD, ST, SFC, FFLD

### PC WORX EXPRESS Order No. [2988670](#)

- Programming for class 100 and AXC 1050 modular small-scale controllers
- Automation system configuration
- INTERBUS module parameterization
- Programming languages supported: FBD, LD, ST
- 128 kbyte I/O data (mix)
- Can be downloaded free of charge

## Easy-to-use ready-made functions

Our drivers and function blocks can be used to integrate numerous functions into your system without any programming effort, such as:

- IT functionality
- Remote function
- SQL connection
- Control technology
- Sector-specific functions

All available function blocks can be found by entering web code #1085 in the search field on our website.

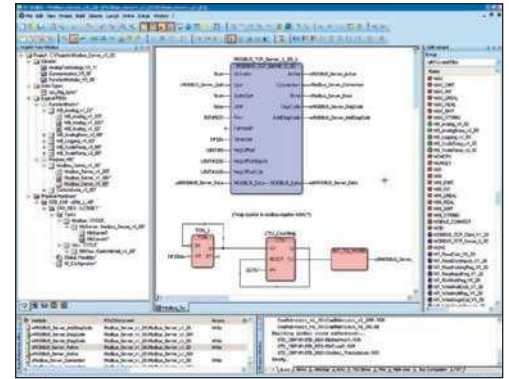

## Safety programming

## Programming logic modules

## Startup and maintenance software

### SAFETYPROG

- **BASIC** Order No. [2700443](#)
- **ADVANCED** Order No. [2700441](#)
- **PROFESSIONAL** Order No. [2700442](#)
- Safe programming system for developing applications for safety controllers
- Based on the IEC 61131-3 standard and fulfills the safety requirements defined in IEC 61508

### LOGIC+

- Intuitive programming for PLC logic
- Function block diagram or ladder diagram
- Numerous integrated function blocks
- Specific function blocks are available to download
- Hardware view in the program
- Can be downloaded free of charge

### Connect+

- Easy initial configuration of controllers from Phoenix Contact
- Simple startup and parameterization of automation projects
- Easy to extend by means of plug-ins (e.g. to configure remote stations according to IEC 60850-5-104)
- Creating and restoring backups of automation projects

# Software: Everything at a glance, thanks to visualization and data management

Whether in the central control room, in the production area or directly on the machine – efficient automation requires the right visualization. In particular, ergonomics and attractiveness make visualization a walking advertisement for your modern machinery. Suitable data management guarantees your systems function optimally.

Benefit from our extensive portfolio for all aspects of operation and monitoring. Phoenix Contact offers software for every application and versatile use on HMI devices and industrial PCs.

## Visu+ offers numerous functions:

- Operation and monitoring
- Trending
- Alarming
- Data logging
- Reporting

Your advantage: common standards for data formats and communication are supported, thanks to the SCADA function of Visu+.

## VISU+

SCADA Visualization

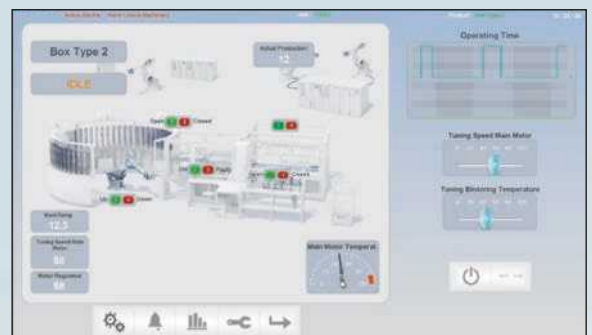
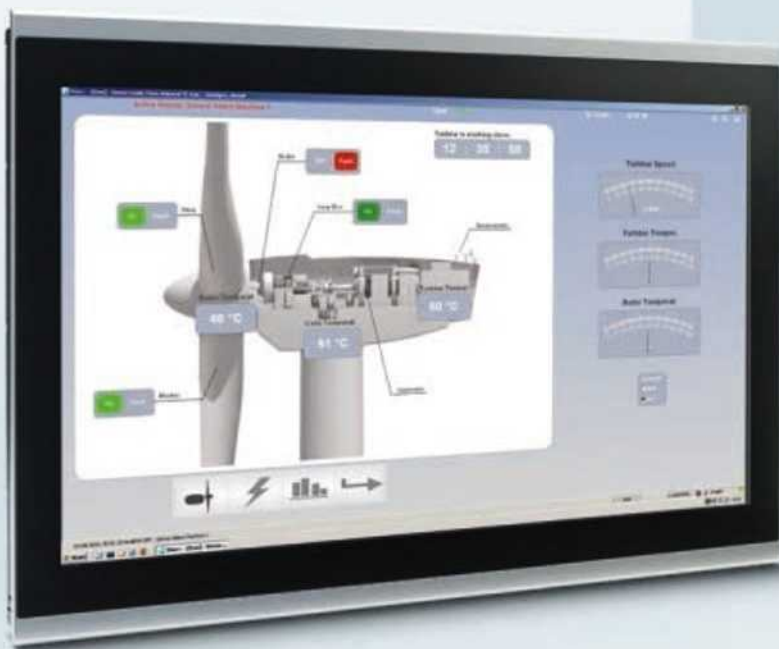

### Visualizing the SCADA class with Visu+

Visualizations with SCADA functions make a good impression thanks to their scalability and versatility. They are used wherever complex machines, systems or automated processes need to be operated and monitored.



## SCADA visualization

## HMI visualization

## Web visualization

**VISU+ 2** Order No. 2988544

- SCADA visualization with OPC or driver connection to the controller
- Efficient engineering
- Alarm and event handling, functions for data logging, trend display, and integrated reporting
- Easy connection to database and ERP systems

**VISU+ 2 EXPRESS** Order No. 2402774

- No license fees
- Time and cost savings, thanks to the simplified user interface
- HMI visualization with OPC or driver connection to the controller
- Alarm and event handling, functions for data logging, trend display, and integrated reporting

**WEBVISIT 6**

- **EXPRESS** Order No. 2700954
- **BASIC** Order No. 2700948
- **PRO** Order No. 2700949

- Visualization editor
- Enables user interfaces to be created quickly
- Easy handling
- Optimally integrates into the workflow, thanks to data coupling with PC Worx and PC Worx EXPRESS



## Visualization app

**VISU+ mobile**

- Convenient: simply use smartphones or tablets for the visualization
- SCADA functions such as trend display or alarm handling are now also available on mobile terminal devices and HMIs
- Easy installation via Google Play Store or Apple App Store
- High level of performance and scalable: up to 100 clients can be operated at the highest configuration level
- Easy handling: all configurations are carried out in the Visu+ development environment

## Operation and monitoring with smart devices

Extend your system visualization to smartphones or tablets with the Visu+ mobile visualization app. You can design flexible operating and monitoring concepts, as the Visu+ mobile app allows you to access your system at any time and from any location. The Visu+ license option required for the app is already enabled on numerous devices, such as the touch panels from Phoenix Contact. Industry PCs with a runtime license for Visu+ simply need to be updated through the addition of the web license option.



# Software: Tools for greater availability

Cost-effective production requires maximum availability. Phoenix Contact offers software tools that not only enable you to start up your system quickly, but also parameterize devices and monitor networks efficiently from any location and diagnose errors rapidly. Suitable for PROFINET or INTERBUS networks as well as lower-level systems such as HART or IO-Link.

A secure configuration tool provides a wide range of functions to efficiently configure systems with INTERBUS and Ethernet networks.

## Your advantages with Diag+:

- Optimally tailored to PROFINET networks
- Displays network errors and the current statuses of controllers and devices
- Preventive diagnostics, such as monitoring the transmission quality of fiber optic paths
- Displays plain text messages, troubleshooting tips or device type information
- Read and display messages from the controller's message archive



## DIAG+ Network Diagnostic

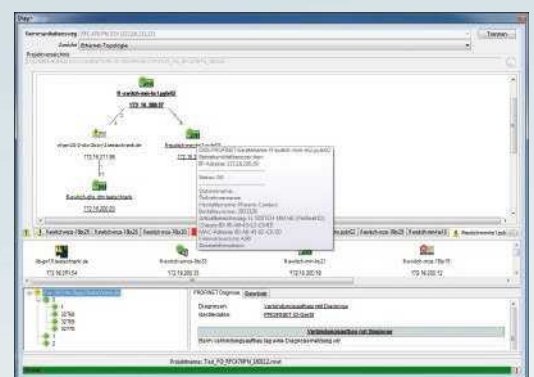

### Detailed system diagnostics with Diag+

The Ethernet/PROFINET topology representation in PC Worx and Diag+ with integrated PROFINET diagnostics clearly displays online accessibility, error statistics, help prompts, and detailed device information.





## Diagnostics software

## Configuration software

### DIAG+

Order No. [2730307](#)

- Extensive PROFINET diagnostic functions
- Fast fault localization
- Fiber optic transmission quality monitoring
- Reading of controller diagnostic archives
- Clear 2D illustration of PROFINET networks
- Tips for error removal

### CONFIG+

Order No. [2868059](#)

- Reading in and comparing the real and configured topology
- Address assignment via drag & drop or completely automatic
- Parameterization of several master boards and controller boards in one project
- IP address assignment via BootP server
- Non-proprietary device parameterization using the FDT/DTM concept
- Monitoring function for wiring checks

## Comprehensive diagnostics for PROFINET networks with Diag+

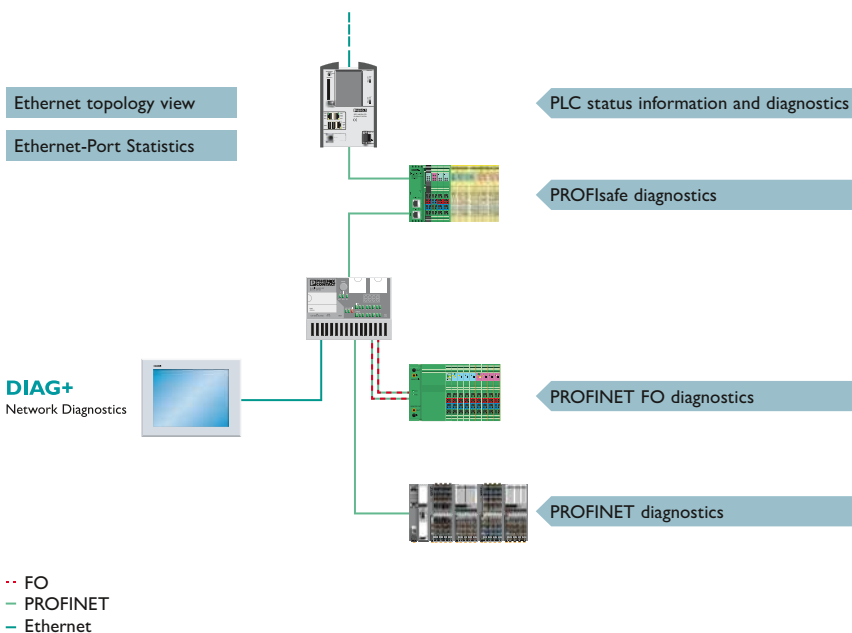

Diag+ is a special diagnostics software tool that has been adapted to PROFINET and indicates both network errors and the current states of controllers and devices. Preventive diagnostic functions such as monitoring the transmission quality of fiber optic paths in PROFINET increase system availability. There are numerous functions for reliable diagnostics, status information, operating functions, plain text messages, and overviews, ensuring fast startup, error localization, and easy orientation in PROFINET and INTERBUS systems.

# Software: The entire technology spectrum from a single source

At Phoenix Contact, you receive consistent automation systems from a single source. In addition to hardware, Phoenix Contact also supplies matching software technology and has a decisive influence in shaping the standards of today's world of automation.

Phoenix Contact software is one of the worldwide leading manufacturers of IEC 61131 software components, ranging from the simple parameterization of small-scale controllers or drives to freely programmable controls for machine building and systems manufacturing. We also set standards in the area of safety-related software technology. More than 50,000 certified systems up to SIL 3 are being used successfully around the world.

## Your benefits

- Complete automation systems from a single source
- Quick reaction times, thanks to broad application expertise
- Maximum flexibility when adapting controller software to your project needs
- In addition to turnkey solutions, if required, you can also receive individual system parts





## IEC 61131 Control

Software Development Kit to develop IEC 61131 controllers.

- Powerful, flexible programming systems
- High controller performance, thanks to native code processing
- Comprehensive debug and startup functions
- Programming in IEC 61131 and C#
- Available for many CPUs and real time operating systems

## IEC 61508 Safety

Software Development Kit to develop IEC 61508 controllers.

- Powerful, flexible programming systems
- High controller performance, thanks to native code processing
- Comprehensive debug and startup functions
- Certified according to IEC 61508, 2nd edition up to SIL 3
- Available for many CPUs and real time operating systems

## PROFINET

Software Development Kit to develop PROFINET devices.

- Powerful, flexible configuration and diagnostics software
- High-performance native Layer 2 implementation
- Extensive debug PROFINET V2.3 controller and device
- Cost-effective TPS-1 single-chip device solution
- Available for many CPUs and real time operating systems

## Technology components for industrial control technology

Our technology components allow you to flexibly implement your own automation solution. With this in mind, we have developed a scalable software platform. Market standards and new technologies are already incorporated into this platform.

An open software architecture with defined interfaces enables the software to be adapted quickly and economically to your specific requirements. The runtime technology components are immediately available for a large number of CPUs and operating systems. They can be quickly adapted to individual device platforms if required. The range of applications spans almost all branches of industry.



### Modular Engineering Platform

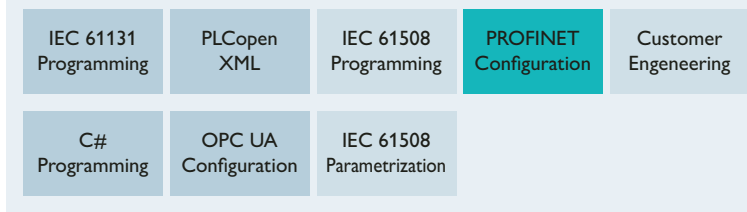

### Modular Runtime Platform

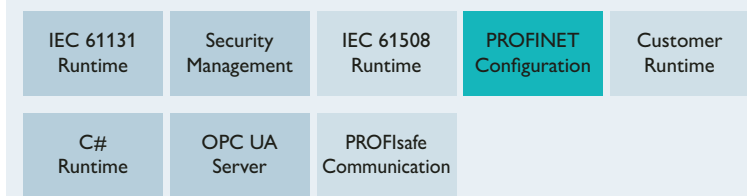

# Service and support: Our services for your success

Whatever the task ahead, the technological solution you are looking for to meet your objective or the products you would like to use: our specialists are always on hand no matter where you are. With our flexible service concept, we support you with regards to all automation technology queries, from applications and systems right through to the topics of industrial security and safety. Our experts have comprehensive industry and technical know-how. This, in combination with Phoenix Contact's wide range of products, means we always have the right solution for you.

**Contact us for more information.**

## Your benefits

- Short response times, thanks to a global network of service experts
- Save time and resources, thanks to comprehensive consulting for your entire system
- Access to expert knowledge, thanks to a wide range of consulting and training services

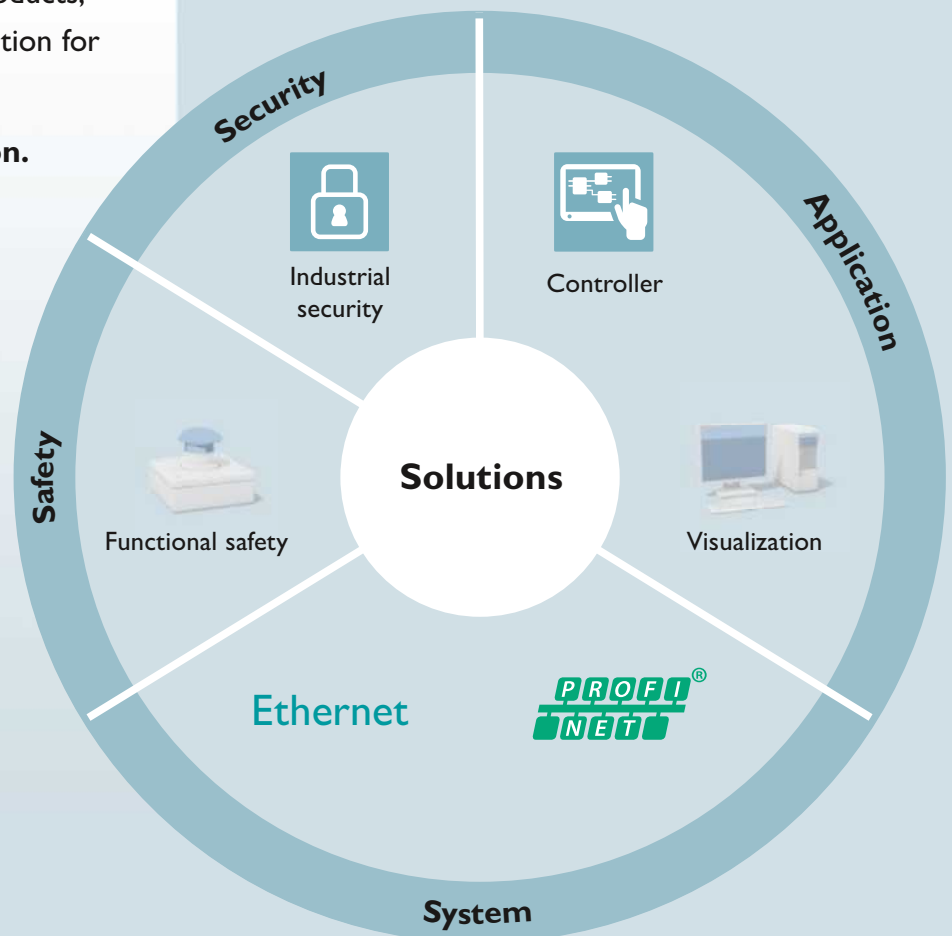



## Consulting

We would be happy to advise you on the best way to plan and optimize your machine or system, sharing our expertise as a system and automation specialist.

### Application and system

Ideally matched to your application: we tailor controller, visualization, PROFINET or other protocols to meet your needs.

### Industrial security

Whether failsafe networks, concepts for safe remote maintenance for your machinery or high-performance wireless networks, we will work out the right solution for you.

### Safety

We provide advice regarding all aspects of the Machinery Directive and guide you through the entire process of acceptance. We provide suggestions to improve existing machines. We also support you in fulfilling safety requirements for systems in the process industry.



## Training and workshops

Thanks to our comprehensive training packages, and the expertise of our trainers, you are always kept right up to date. We are glad to match individual workshops to your needs.

### Application and system

Whether it is planning, implementation or diagnostics – we have the right training package for you to answer every question about our controller and visualization technology.

### Industrial security

In instructional courses and practical training sessions, we prepare you and your employees for failsafe networks.

### Safety

We train you on all aspects of the EN ISO 13849-1 Machinery Directive, SISTEMA, the safety lifecycle, IEC 61511 and PROFIsafe; as an in-house workshop, if you wish.



## Engineering

Benefit from our experience and our network of project engineers and system partners in all phases of your project.

### Application and system

We support you throughout the implementation of your system or partial application with Phoenix Contact.

### Industrial security

We offer support during the configuration and startup phases of your network and show you how to optimize it.

### Safety

We provide support over the entire process, from assessing the safety integrity and programming the safe controller to verification and validation. Based on our template documents, which conform to current standards and directives, we will create the technical documents for proof of the safety of machinery for you.



Whether by phone, via remote access or on site – Phoenix Contact is there for you.

### Application, systems, and industrial security:

Hotline available 24 hours/365 days:

**+ 49 5281 9-462888**

E-mail:

**[automation-service@phoenixcontact.com](mailto:automation-service@phoenixcontact.com)**

### Safety







Hotline available 24 hours/365 days:







**+ 49 5281 9-462777**



E-mail:

**[safety-service@phoenixcontact.com](mailto:safety-service@phoenixcontact.com)**

# Selection tables and technical data

		PLC logic programmable logic modules		Modular controllers (class 100)				
								
		PLC-V8C SAM	PLC-V8C BM	ILC 131 ETH	ILC 131 ETH/XC	ILC 151 ETH	ILC 151 ETH/XC	ILC 151 GSM/GPRS
		2905136	2905135	2700973	2701034	2700974	2701141	2700977
General data	Processor	ARM Cortex-M3		Altera Nios II		Altera Nios II		
	Clock frequency	96 MHz		64 MHz		64 MHz		
	Program memory	256 kbyte		192 kbyte		256 kbyte		512 kbyte
	Storage	12 kbyte		192 kbyte		256 kbyte		512 kbyte
	Retentive mass storage	108 byte		8 kbyte		8 kbyte		48 kbyte
	I/O points	16 kbit	16 kbit ... 48 kbit	2 kbit ... 10 kbit		4 kbit ... 16 kbit		
	Programming tool	Logic+		PC Worx / PC WORX EXPRESS		PC Worx / WORX EXPRESS		
	Temperature range	-20°C ... +45°C		-25°C ... +55°C	-40°C ... +60°C	-25°C ... +55°C	-40°C ... +60°C	-25°C ... +55°C
INTER-BUS	Local bus device	-		63		63		
	Total devices	-		63		128		
PROFI-NET	Device (controller)	-		-		-		
	Device	Yes		Yes		Yes		
Modbus/TCP	Device (client)	-		4		8		
	Server	-		Yes (FW 4.42 or later)		Yes (FW 4.42 or later)		
Direct inputs/outputs	Digital inputs/outputs	8/8		8/4		8/4		16/4
	Analog inputs/outputs	2/0		-		-		-
	Incremental encoder input	-		-		-		-
	Fast counters	-		-		-		-
Interfaces	PWM or pulse/direction outputs	-		-		-		-
	Ethernet interface	-		1		1		-
	RS-232 interface	-		1		1		-
	RS-485 interface	-		-		-		-
	USB host	-		-		-		-
Adj. mem.	Micro USB B	1		-		-		-
	Plug-in	Yes		SD (up to 2 Gbyte)		SD (up to 2 Gbyte)		
	License key	Yes		Yes		Yes		
		Modular controllers (class 1000)		Modular controllers (class 3000)		Software PLC		
								
		AXC 1050	AXC 1050 / XC	AXC 3050		PC WORX SRT	PC WORX RT BASIC	
		2700988	2701295	2700989		2701680	2700291	
General data	Processor	Altera Nios II		Intel® Atom™ E660		Depending on the industrial PC used		
	Clock frequency	100 MHz		1.30 GHz		Depending on the industrial PC used		
	Program memory	1 Mbyte		4 Mbyte		1 Mbyte		8 Mbyte
	Mass storage	2 Mbyte		8 Mbyte		1 Mbyte		16 Mbyte
	Retentive mass storage	48 kbyte		128 kbyte		48 kbyte		240 kbyte
	I/O points	4 kbit ... 36 kbit		4 kbit ... 36 kbit		8 kbit ... 28 kbit (Depending on the industrial PC used)		8 kbit ... 512 kbit (Depending on the industrial PC used)
	Programming tool	PC Worx / PC WORX EXPRESS		PC Worx		PC Worx / PC WORX EXPRESS		PC Worx
	Temperature range	-25°C ... +60°C	-40°C ... +70°C	-25°C ... +60°C		Depending on the industrial PC used		
INTER-BUS	Local bus device	-		-		-		
	Total devices	-		-		-		512 (Can be extended with PCI-SC card as an option)
PROFI-NET	Device (controller)	8 (selectable)		256		max. 10		max. 256
	Device	Selectable		Yes		Yes		-
Modbus/TCP	Device (client)	16		32		32		-
	Server	-		-		-		-
Direct inputs/outputs	Local bus device	63		63		-		-
	Digital inputs/outputs	-		-		3/3 (only on a BPC Mini)		-
	Fast counters	-		Yes		-		-
	PWM or pulse/direction outputs	-		-		-		-
Interfaces	Ethernet interface	2		3		1		1
	RS-232 interface	-		-		1		-
	RS-485 interface	-		-		-		-
	USB host	-		1		-		1
	Micro USB B	1		1		-		-
Adj. mem.	Plug-in	SD (up to 2 Gbyte)		SD (up to 2 Gbyte)		-		-
	License key	Yes		Yes		-		-

		Modular controllers (class 100)				Modular controllers (class 300)		
								
		<b>ILC 171 ETH 2TX</b>	<b>ILC 191 ETH 2TX</b>	<b>ILC 191 ETH ME/AN</b>	<b>ILC 191 ETH ME/INC</b>	<b>ILC 350 PN</b>	<b>ILC 370 PN 2TX-IB/M</b>	<b>ILC 390 PN 2TX-IB</b>
		<b>2700975</b>	<b>2700976</b>	<b>2700074</b>	<b>2700075</b>	<b>2876928</b>	<b>2985576</b>	<b>2985314</b>
General data	Processor	Altera Nios II		Altera Nios II		PXA 255	PXA 255	PXA 270
	Clock frequency	64 MHz		64 MHz		400 MHz	400 MHz	624 MHz
	Program memory	512 kbyte		1 Mbyte		1 Mbyte	2 Mbyte	2 Mbyte
	Storage	512 kbyte		1 Mbyte		2 Mbyte	4 Mbyte	4 Mbyte
	Retentive mass storage	48 kbyte		48 kbyte		64 kbyte	96 kbyte	96 kbyte
	I/O points	4 kbit ... 36 kbit		4 kbit ... 36 kbit		8 kbit ... 210 kbit		
	Programming tool	PC Worx / PC WORX EXPRESS		PC Worx / PC WORX EXPRESS		PC Worx		
	Temperature range	-25 °C ... +55 °C		-25 °C ... +55 °C		-25 °C ... +55 °C		
Modbus/PROFI-INTER-BUS	Local bus device	63		63		63		
	Total devices	128		128		512		
TCP	Device (controller)	-		-		100		
	Device	Yes		Yes		Yes		
TCP	Device (client)	16		16		-		
	Server	Yes (FW 4.42 or later)		Yes (FW 4.42 or later)		-		
Direct inputs/outputs	Digital inputs/outputs	8/4		8/4		12/4		
	Analog inputs/outputs	-		2/2		-		
	Incremental encoder input	-		-		2		
	Fast counters	-		-		2		
	PWM or pulse/direction outputs	-		2		-		
Interfaces	Ethernet interface	2		2		1	2	2
	RS-232 interface	1		1		1		
	RS-485 interface	-		1		-		
	USB host	-		-		-		
	Micro USB B	-		-		-		
Adj. mem.	Plug-in	SD (up to 2 Gbyte)		SD (up to 2 Gbyte)		CF (up to 2 Gbyte), required for operation		
	License key	Yes		Yes		Yes		

		Compact controllers			
					
		<b>RFC 460R PN 3TX</b>	<b>RFC 470 PN 3TX</b>	<b>RFC 470S PN 3TX</b>	
		<b>2700784</b>	<b>2916600</b>	<b>2916794</b>	
General data	Processor	Intel® Celeron® M ULV 423		Intel® Celeron® 927UE	
	Clock frequency	800 MHz		1.50 GHz	
	Program memory			8 Mbyte	
	Mass storage			16 Mbyte	
	Retentive mass storage	120 kbyte		240 kbyte	
	I/O points	Max. 512 kbit		8 kbit ... 512 kbit	
	Programming tool	PC Worx			
	Temperature range	0 °C ... +45 °C (up to +55 °C with fan)			
Modbus/PROFI-INTER-BUS	Local bus device	-		-	
	Total devices	-		512	
TCP	Device (controller)	-		256	
	Device	-		Yes	
TCP	Device (client)	-		-	
	Server	-		-	
Direct inputs/outputs	Local bus device	-		-	
	Digital inputs/outputs	-		5/3	
	Fast counters	-		-	
	PWM or pulse/direction outputs	-		-	
	Ethernet interface	-		3	
Interfaces	RS-232 interface	-		1	
	RS-485 interface	-		-	
	USB host	-		2	
	Micro USB B	-		-	
Adj. mem.	Plug-in	CF (up to 2 Gbyte), required for operation			
	License key	Yes			



Always up-to-date, always available to you. Here you'll find everything on our products, solutions and service:

[phoenixcontact.com](http://phoenixcontact.com)

## Product range

- Cables and wires
- Charging technology for E-Mobility
- Connectors
- Controllers
- Electronics housings
- Electronic switchgear and motor control
- Fieldbus components and systems
- Functional safety
- HMIs and industrial PCs
- I/O systems
- Industrial communication technology
- Installation and mounting material
- Lighting and signaling
- Marking and labeling
- Measurement and control technology
- Monitoring
- PCB terminal blocks and PCB connectors
- Power supply units and UPS
- Protective devices
- Relay modules
- Sensor/actuator cabling
- Software
- Surge protection and interference filters
- System cabling for controllers
- Terminal blocks
- Tools

PHOENIX CONTACT GmbH & Co. KG  
Flachsmarktstraße 8  
32825 Blomberg, Germany  
Phone: +49 52 35 3-00  
Fax: +49 52 35 3-4 12 00  
E-mail: [info@phoenixcontact.com](mailto:info@phoenixcontact.com)  
[phoenixcontact.com](http://phoenixcontact.com)